



Assembly Instructions For Motorizing WAG, WAA, WAGC & WAAC Single & Double Panel Backdraft Dampers



This CAM motor operation package consists of four major components; motor with base, CAM assembly (with pull spring, CAM pulley and spring retainer) and hardware. Follow steps in sequence for best results.

Make all electric connections using good wiring practices and in accordance with National Electric Code and any local codes.

HINTS (A) On new installations, assembly of the motorizing kit would be more easily done prior to installing the damper.

(B) **DO NOT ATTACH THE CAM OPERATOR TO THE MOTOR UNTIL THE CAM ASSEMBLY IS ATTACHED TO THE BACKDRAFT DAMPER LADDER BAR AND THE MOTOR IS ATTACHED TO THE BACKDRAFT DAMPER FRAME.**

SINGLE PANEL INSTRUCTIONS

1. Refer to Chart 2 on page 5 for proper retainer hole location. Attach the pull spring retainer to the backdraft damper ladder bar using two (2) bolts and lock nuts. Opening the unit will give easy access to the ladder bar.
2. Mount the motor and base using three (3) No. 8 screws (and three (3) speed nuts on aluminum frames) by aligning the slots in the motor with the three (3) holes in the frame. (Note: On some models the backdraft damper frame is not pre-drilled. In this case, use the motor base as a template to locate the proper locations. For single panel units, the motor base should fit in the lower left corner of the backdraft damper as viewed from the inlet side. The motor base should be square to the backdraft damper. Self drilling screws can be used to secure the motor base to the backdraft damper frame. As an alternate to the self drilling screws, .125" diameter holes can be pre-drilled to use the #8 screws provided in the motor kit.
3. Attach the CAM pulley to the motor shaft. Position the CAM assembly so that approximately 1/8" of the motor shaft is showing through the CAM pulley, then tighten the cam clamp bolt.
4. Check to see that all other bolts in the assembly are tight.

Step 1 **TOP VIEW**

IMPORTANT
ASSEMBLE IN THIS MANNER:
Bolt through ladder bar first, then retainer, then lock nut.

Step 2

Step 3

DOUBLE PANEL INSTALLATION - WAGC & WAAC

Step 1

Refer to chart 1 for proper retainer hole location. Attach the pull spring retainer to the backdraft damper ladder bar using two (2) bolts and lock nuts. Opening the unit will give easy access to the ladder bar.

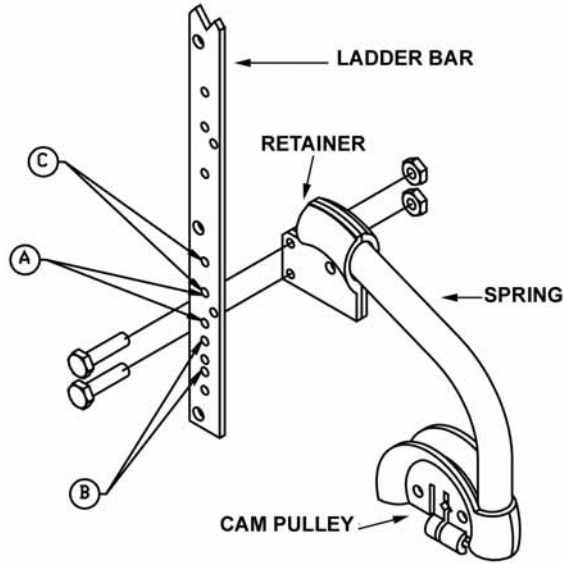

IMPORTANT

ASSEMBLE IN THIS MANNER:

Bolt through the ladder bar first, then retainer, then lock nuts.

CHART 1			
MATCH RETAINER HOLE LOCATION TO BACKDRAFT DAMPER MODEL SIZE BELOW			
A	B	C	C
	4040	4141	4242
4343	4444	4545	4646
4747	4848	4949	5050
5151	5252	5353	5454
5555	5656	5757	5858
5959	6060	6161	6318
6363	6340	6565	6362
6767	6464	6969	6262
7171	6868		6666
	7272		7070

Step 2

Mount the motor and base as shown using three (3) No. 8 screws (and three (3) speed nuts on aluminum frames) by aligning the slots in the base with the three (3) holes in the frame and center bar.

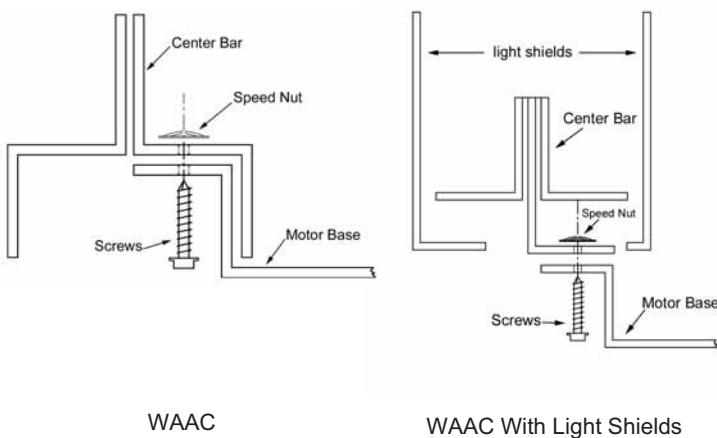

Step 3

Attach the CAM pulley to the motor shaft. Position the CAM assembly so that approximately 1/8" of the motor shaft is showing through the CAM pulley then tighten the Cam clamp bolt.

BACKDRAFT DAMPER INSTALLATION - WAGC, WAAC, WAA & WAG

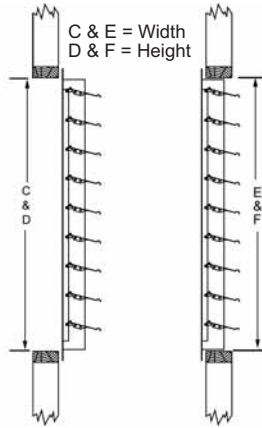

Outside Wall

Thru Wall

Be sure the bottom blade does not rub the framing.

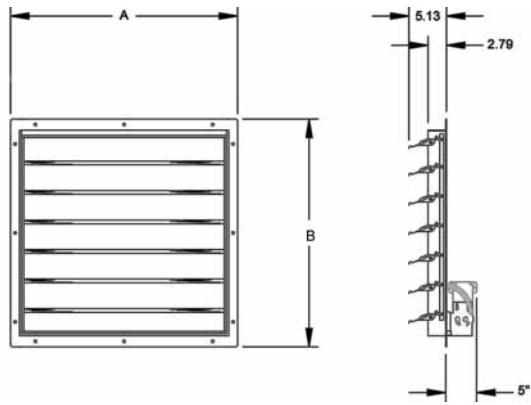

MODEL	Outside Wall		Thru-Wall		Number of Panels	Number of Motors		
	A	B	C	D			E	F
	IN	IN	IN	IN			IN	IN
1212	12.00	12.00	9.00	9.00	9.75	10.32	1	1
1313	13.00	13.00	10.00	10.00	10.75	11.32	1	1
1414	14.00	14.00	11.00	11.00	11.75	12.32	1	1
1515	15.00	15.00	12.00	12.00	12.75	13.32	1	1
1616	16.00	16.00	13.00	13.00	13.75	14.32	1	1
1717	17.00	17.00	14.00	14.00	14.75	15.32	1	1
1818	18.00	18.00	15.00	15.00	15.75	16.32	1	1
1919	19.00	19.00	16.00	16.00	16.75	17.32	1	1
2020	20.00	20.00	17.00	17.00	17.75	18.32	1	1
2121	21.00	21.00	18.00	18.00	18.75	19.32	1	1
2222	22.00	22.00	19.00	19.00	19.75	20.32	1	1
2323	23.00	23.00	20.00	20.00	20.75	21.32	1	1
2424	24.00	24.00	21.00	21.00	21.75	22.32	1	1
2525	25.00	25.00	22.00	22.00	22.75	23.32	1	1
2626	26.00	26.00	23.00	23.00	23.75	24.32	1	1
2727	27.00	27.00	24.00	24.00	24.75	25.32	1	1
2828	28.00	28.00	25.00	25.00	25.75	26.32	1	1
2929	29.00	29.00	26.00	26.00	26.75	27.32	1	1
3030	30.00	30.00	27.00	27.00	27.75	28.32	1	1
3131	31.00	31.00	28.00	28.00	28.75	29.32	1	1
3232	32.00	32.00	29.00	29.00	29.75	30.32	1	1
3333	33.00	33.00	30.00	30.00	30.75	31.32	1	1
3434	34.00	34.00	31.00	31.00	31.75	32.32	1	1
3535	35.00	35.00	32.00	32.00	32.75	33.32	1	1
3636	36.00	36.00	33.00	33.00	33.75	34.32	1	1
3737	37.00	37.00	34.00	34.00	34.75	35.32	1	1
3838	38.00	38.00	35.00	35.00	35.75	36.32	1	1
3939	39.00	39.00	36.00	36.00	36.75	37.32	1	1
4040	40.00	40.00	37.00	37.00	37.75	38.32	*2	1
4141	41.00	41.00	38.00	38.00	38.75	39.32	2	1
4242	42.00	42.00	39.00	39.00	39.75	40.32	2	1
4343	43.00	43.00	40.00	40.00	40.75	41.32	2	1
4444	44.00	44.00	41.00	41.00	41.75	42.32	2	1
4545	45.00	45.00	42.00	42.00	42.75	43.32	2	1
4646	46.00	46.00	43.00	43.00	43.75	44.32	2	1
4747	47.00	47.00	44.00	44.00	44.75	45.32	2	1
4848	48.00	48.00	45.00	45.00	45.75	46.32	2	1
4949	49.00	49.00	46.00	46.00	46.75	47.32	2	1
5050	50.00	50.00	47.00	47.00	47.75	48.32	2	1
5151	51.00	51.00	48.00	48.00	48.75	49.32	2	1
5252	52.00	52.00	49.00	49.00	49.75	50.32	2	1
5353	53.00	53.00	50.00	50.00	50.75	51.32	2	1
5454	54.00	54.00	51.00	51.00	51.75	52.32	2	1
5555	55.00	55.00	52.00	52.00	52.75	53.32	2	1
5656	56.00	56.00	53.00	53.00	53.75	54.32	2	1
5757	57.00	57.00	54.00	54.00	54.75	55.32	2	1
5858	58.00	58.00	55.00	55.00	55.75	56.32	2	1
5959	59.00	59.00	56.00	56.00	56.75	57.32	2	1
6060	60.00	60.00	57.00	57.00	57.75	58.32	2	1
6161	61.00	61.00	58.00	58.00	58.75	59.32	2	1
6262	62.00	62.00	59.00	59.00	59.75	60.32	2	1
6318	63.00	18.00	60.00	15.00	60.75	16.32	2	1
6340	63.00	40.00	60.00	37.00	60.75	38.32	2	1
6362	63.00	62.00	60.00	59.00	60.75	60.32	2	1
6363	63.00	63.00	60.00	60.00	60.75	61.32	2	1

The framed opening can be calculated for backdraft damper sizes not shown. For units mounted outside the wall, subtract 3 inches from the width and height dimension of the backdraft damper. For units mounted through the wall, subtract 2.25 inches from the width and subtract 1.68 inches from the height. Be sure the bottom blade does not rub the framing.

*WAGC and WAAC 1 Panel

DOUBLE PANEL INSTALLATION - WAG & WAA

Step 1

Refer to chart 2 for proper retainer hole location. Attach the pull spring retainer to the backdraft damper ladder bar using two (2) bolts and lock nuts. Opening the backdraft damper will give easy access to the ladder bar.

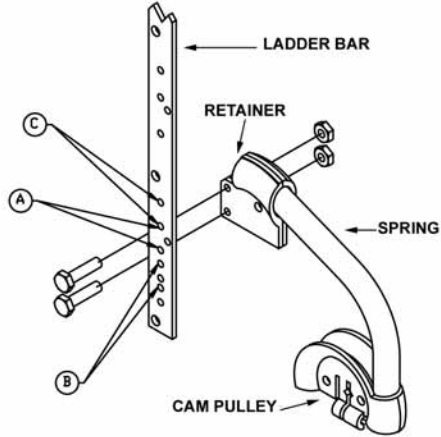

IMPORTANT

ASSEMBLE IN THIS MANNER:

Bolt through the ladder bar first, then retainer, then lock nuts.

Step 2

Mount the motor and base as shown using three (3) No. 8 screws (and three (3) speed nuts on aluminum frames) by aligning the slots in the base with the three (3) holes in the frame and center bar.

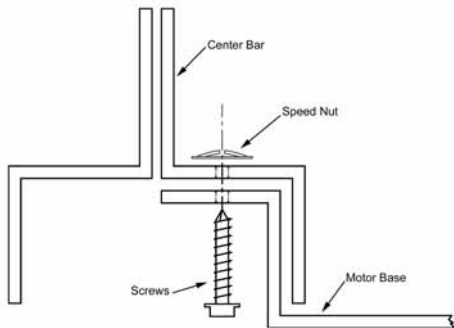

Step 3

Attach the CAM pulley to the motor shaft. Position the CAM assembly so that approximately 1/8" of the motor shaft is showing through the CAM pulley then tighten the CAM clamp bolt.

Step 4 (For Existing Installation)

Attach the panel connecting link to the two center ladder bars, at the holes provided, using four (4) No. 8 x 5/8" bolts and lock nuts.

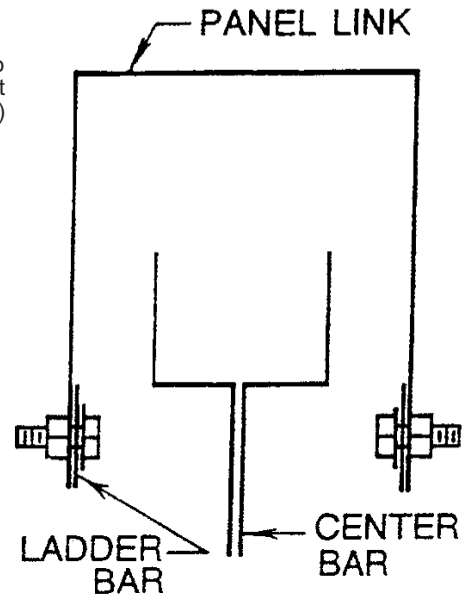

IMPORTANT

Assemble in this manner. bolt through ladder bar first, then panel link, then lock nuts.



NOTE: Return Spring is not required on this unit.

BACKDRAFT DAMPER - WAG & WAA

Preparing Backdraft Damper For Existing Installations

Mounting holes need to be provided to the motor base in the backdraft damper frame and center bar (double panel) and for the spring retainer in the ladder bar.

1. USING THE MOTOR BASE AS A TEMPLATE.

A. On single panel units, drill (3) holes in the lower left hand corner of the backdraft damper frame:

B. On double panel units, drill (2) holes in the center bar on the right hand leg and (1) hole in the backdraft damper frame. Be sure to locate the motor base inside the channel of the center bar. (See step 2, Page 2)

2. Locate the backdraft damper size (outside dimensions) on the chart below and select the proper retainer hole locations. Mark the ladder bar and drill (2) 11/16" holes.

3. Follow assembly instructions on page 1 (single panel) or page 2 (double panel) to complete the installation.

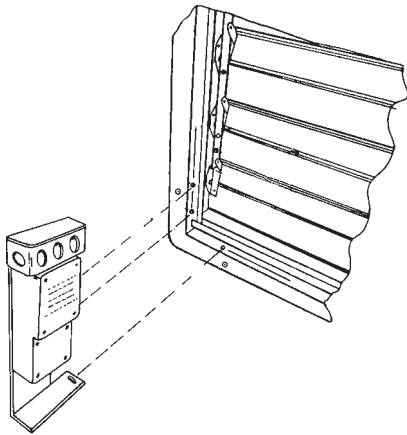

SINGLE PANEL

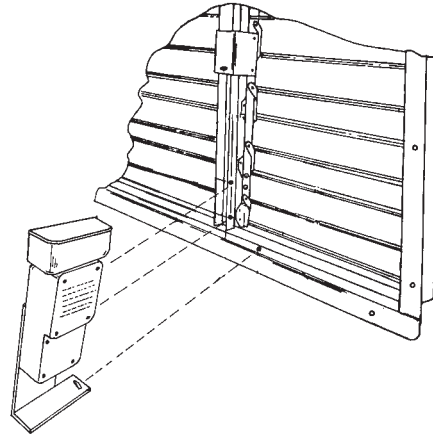

DOUBLE PANEL

CHART 2
MATCH RETAINER HOLE LOCATION TO BACKDRAFT DAMPER MODEL SIZE BELOW

A	B	C	C
2 9/32"	1 1/4"	2 15/16"	2 15/16"
	1212	1313	1414
1515	1616	1717	1818
1919	2020	2121	2222
2323	2424	2525	2626
2727	2828	2929	3030
3131	3232	3333	3434
3535	3636	3737	3838
3939	4040	4141	4242
4343	4444	4545	4646
4747	4848	4949	5050
5151	5252	5353	5454
5555	5656	5757	5858
5959	6060	6161	6318
6363	6340	6565	6362
6767	6464	6969	6262
7171	6868		6666
	7272		7070

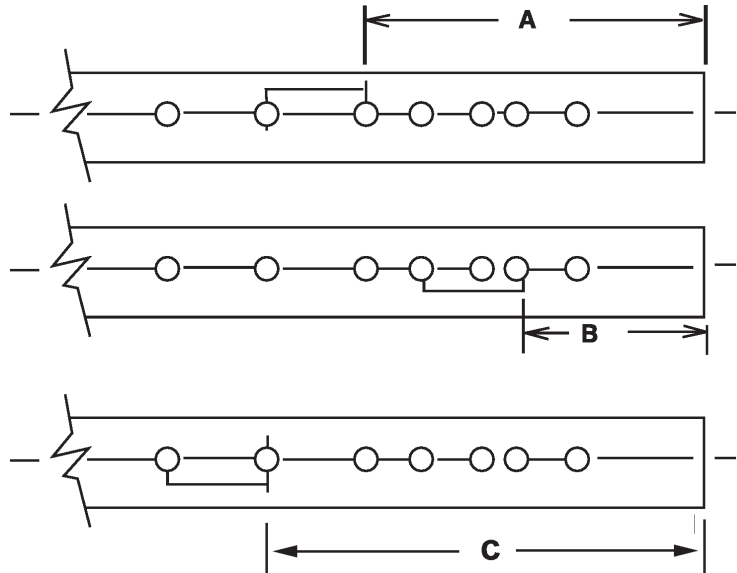

Sizes 12-39 are single panel units and the remaining sizes are double panel units.

ELECTRICAL CONNECTIONS

Make all electrical connections using good wiring practices and in accordance with National Electric Code and any local code.

When using this motor in a moist environment, incorporate a drip loop in the wiring and/or conduit to prevent water from tracking into the junction box.

When wiring is complete, caulk the wire passage from the junction box into the motor. This will extend the life of the motor.

WARNING

To prevent excessive gaps or binding between the backdraft damper frame and the blades, the following must be observed.

1. Backdraft Damper mounting frame surface must be flat and parallel to the mounting surface of the unit.
2. Backdraft Damper sides, top and bottom must be straight and parallel when mounted to the framed mounting surface.

TERMS AND CONDITIONS OF SALE

ACCEPTANCE All orders and sales are subject to written approval and acceptance by an executive officer of Acme Engineering & Manufacturing Corporation at Muskogee, Oklahoma, (the "Company") and are not binding on the Company until so approved.

DELIVERY All shipping and delivery dates are estimated only. No delays in delivery will subject the Company to any costs, damages or fees for late delivery. Delivery of the products herein specified shall be made F.O.B. point of shipment, unless otherwise stated. The Company shall not be liable for delay due to causes beyond its reasonable control, such as Acts of God, acts of the purchaser, acts of civil or military authorities, priorities, fires, strikes, floods, epidemics, war, riots, delays in transportation, car shortages, and inability, due to reasons beyond its reasonable control, to obtain necessary labor, material, or manufacturing facilities. In the event of such a delay, the date of delivery shall be extended for a period equal to the time lost by reason of the delay.

TERMS OF PAYMENT If, in the judgment of the Company, the financial condition of the purchaser at any time does not justify continuation of manufacture or shipment on the terms of payment specified, the Company may require full or partial payment in advance.

Pro rata payments shall become due as shipments are made. Each shipment or delivery shall constitute a separate sale, and the default of any shipment or delivery shall constitute a separate sale, and the default of any shipment or delivery shall not vitiate the contract as to other shipments or deliveries.

SALES AND SIMILAR TAXES The Company's prices do not include sales, use, excise, or similar taxes. Consequently, in addition to the price specified herein, the amount of any present or future sales, use, excise, or

other similar tax applicable to the sale of the product herein shall be paid by the Purchaser, or in lieu thereof the Purchaser shall provide the Company with a tax exemption certificate acceptable to the taxing authorities.

CANCELLATION Any contract resulting from the Purchaser's order may be canceled by the Purchaser only by negotiations and upon payments of reasonable cancellation charges which will take into account expenses already incurred and commitments made by the Company.

DESIGN CHANGES The Company reserves the right to make changes in design, improvements and additions in and to its products any time without imposing any liability or obligations to itself to apply or install the same in any product manufactured by it.

TITLE The title and right of possession of the products sold herein shall remain with the Company and such products shall remain personal property until all payments herein (including deferred payments whether evidenced by notes or otherwise) shall have been made in full in cash and the Purchaser agrees to do all acts necessary to perfect and maintain such right and title in the Company.

PRICE ADJUSTMENTS Prices are subject to change upon notice by the Company. Prices on existing orders are subject to surcharges in the event of cost increases of metals and transportation. All complete component accessory material manufactured by others and furnished with the Company's products such as motors, drives, vibration equipment, controls or other completely assembled component structures, are subject to adjustment to the price at time of shipment regardless of the date of original order entry.

SAFETY ACCESSORIES The Company manufactures products designed to serve multiple applications and of-

fers a wide range of safety equipment, including guards and other devices, as may be required to meet customer specifications. Without exception, the Company recommends that all orders include applicable safety devices. Products ordered without applicable safety devices is clearly the responsibility of the Purchaser. Further, the Purchaser warrants that it has determined and acquired any and all safety devices required for products sold by the Company. Weather covers and guards for motor and V-belt drives, couplings, shafts and bearings, along with inlet and outlet screens, are optional accessories noted in the price list.

GOVERNING LAW The rights, obligations and remedies of Purchaser and the Company, the interpretation of these terms and conditions and the sale of products by the Company shall be governed by Oklahoma law, without regard to any principles of conflict of laws.

ARBITRATION Any dispute arising under or in connection with these terms and conditions or the sale of products shall be settled by binding arbitration administered by the American Arbitration Association under its Commercial Arbitration Rules, and judgment on the award rendered by the arbitrator may be entered in any court having jurisdiction thereof. The dispute shall be resolved by one neutral arbitrator who shall have no affiliation with either Purchaser or the Company and shall be selected by the American Arbitration Association office in Dallas, Texas. The arbitration proceedings shall be held in Muskogee, Oklahoma.

APPLICABLE DOCUMENTS The agreement between the Company and the Purchaser relating to the products includes these terms and conditions of sale, any applicable installation and maintenance instructions provided by the Company and any terms appearing on the Company's quotation, sales order acknowledgment and invoice.

WARNING Acme products are designed and manufactured to provide reliable performance but they are not guaranteed to be 100% free of defects. Even reliable products will experience occasional failures and this possibility should be recognized by the Purchaser and all End Users. If these products are used in a life support ventilation system where failure could result in loss or injury, the Purchaser and all End Users should provide adequate back-up ventilation, supplementary natural ventilation or failure alarm system, or acknowledge willingness to accept the risk of such loss or injury.

WARNING DO NOT use in HAZARDOUS ENVIRONMENTS where fan's electrical system could provide ignition to combustible or flammable materials unless unit is specifically built for hazardous environments. Comply with all local and national safety codes including the National Electrical Code (NEC) and National Fire Protection Act (NFPA).

CAUTION Guards must be installed when fan is within reach of personnel or within eight (8) feet (2.5 m) of working level or when deemed advisable for safety.

DISCLAIMER The Company has made a diligent effort to illustrate and describe the products accurately in all Company literature; however such illustrations and descriptions are for the sole purpose of identification and do not express or imply any warranty.

LIMITED WARRANTY

WARRANTY AND DISCLAIMER: the Company extends this limited warranty to the original purchaser and warrants that products supplied by the Company, shall be free from original defects in workmanship and materials for two years from date of shipment (except for the warranty periods noted for products listed below), provided same have been properly handled, stored, installed, serviced, maintained and operated. This warranty shall not apply to products which have been altered or repaired without the Company's express authorization, or altered or repaired in any way so as, in the Company's judgment, to affect its performance or reliability, nor which have been improperly installed or subjected to misuse, negligence, or accident, or incorrectly used in combination with other substances. The Purchaser assumes all risks and liability for results of use of all products.

Evaporative cooling pads are warranted to be free of defects in materials and workmanship for a period of two years from date of shipment provided same have been properly handled, stored, installed, serviced, maintained and operated; and further, not subjected to excessive heat, corrosive agents or chemicals, or mechanical abuse that may cause tearing, crushing or undue deterioration, nor used on a system or in a manner other than that for which it was designed as explained in the product literature.

The following products are warranted to be free of defects in materials and workmanship for the periods shown from date of shipment: Acme's exclusive duplex split pillow block bearings and shaft five years, belts one year, Polyethylene tubing 90 days, AIR40 Heater warranty one year, AIR40 Emitter warranty three years and DDP fan lifetime warranty on its propeller, cone, and housing.

LIMITATION OF REMEDY AND DAMAGES: All claims under this warranty must be made in writing and delivered to P. O. Box 978, Muskogee, Oklahoma, 74402, within 15 days after discovery of the defect and prior to the expiration of two years from the date of shipment by the Company of the product claimed defective, and Purchaser shall be barred from any remedy if Purchaser fails to make such claim within such period.

Within 30 days after receipt of a timely claim, the Company shall have the option either to inspect the product while in Purchaser's possession or to request Purchaser to return the product to the Company at Purchaser's ex-

pense for inspection by the Company. The Company shall replace, or at its option repair, free of charge, any product it determines to be defective, and it shall ship the repaired or replacement product to Purchaser F.O.B. point of shipment; provided, however, if circumstances are such as in the Company's judgment to prohibit repair or replacement to remedy the warranted defects, the Purchaser's sole and exclusive remedy shall be a refund to the Purchaser of any part of the invoice price, paid to the Company, for the defective product or part.

The Company is not responsible for the cost of removal of the defective product or part, damages due to removal, or any expenses incurred in shipping the product or part to or from the Company's plant, or the installation of the repaired or replaced product or part.

The warranties set forth above do not apply to any components, accessories, parts or attachments manufactured by other manufacturers; such being subject to the manufacturer's warranty, if any. To the extent not prohibited by the manufacturer's warranty, the Company shall pass through to Purchaser such manufacturer's warranty.

THE COMPANY'S WARRANTY IS IN LIEU OF ALL OTHER WARRANTIES, EXPRESS OR IMPLIED, ARISING BY LAW OR OTHERWISE, INCLUDING WITHOUT LIMITATION THE IMPLIED WARRANTIES OF MERCHANTABILITY AND FITNESS FOR A PARTICULAR PURPOSE, WHICH ARE HEREBY EXPRESSLY DISCLAIMED AND WAIVED. THIS WARRANTY CONSTITUTES THE COMPANY'S SOLE AND EXCLUSIVE WARRANTY FOR DEFECTIVE GOODS AND PURCHASER'S SOLE AND EXCLUSIVE REMEDY FOR DEFECTIVE PRODUCTS.

No employee, agent, dealer, or other person is authorized to give any warranties on behalf of the Company or to assume for the Company any other liability in connection with any of its products except in writing and signed by an officer of the Company.

REPLACEMENT PARTS If replacement parts are ordered, purchaser warrants that the original components in which these replacement parts will be placed are in satisfactory working condition, and when said replacement parts are installed, the resultant installation will operate in a safe manner, at speeds and temperatures for which the original product was purchased.

TECHNICAL ADVICE AND RECOMMENDATIONS, DISCLAIMER: Notwithstanding any past practice or dealings or any custom of the trade, sales shall not include the furnishing of technical advice or assistance or system design. Any such assistance shall be at the Company's sole option and may be subject to additional charge.

The Company assumes no obligation or liability on account of any recommendations, opinions or advice as to the choice, installation or use of products. Any such recommendations, opinions or advice are given and shall be accepted at Purchaser's and End User's risk and shall not constitute any warranty or guarantee of such products or their performance.

LIMITATION OF LIABILITY The cumulative liability of the Company to the Purchaser and any other persons for all claims in any way relating to or arising out of the products, including, but not limited to, any cause of action sounding in contract, tort, or strict liability, shall not exceed the total amount of the purchase price paid for those products which are the subject of any such claim. This limitation of liability is intended to apply without regard to whether other provisions of this agreement have been breached or have proven ineffective even if the Company has been advised of the possibility of such claims or demands. In no event shall the Company be liable to the Purchaser or any other person for any loss of profits or any incidental, special, exemplary, or consequential damages for any claims or demands brought by the Purchaser or such other persons.

INDEMNITY The Company's maximum liability to Purchaser and to any end user is as set forth above. The Company makes no warranty to anyone for any products not manufactured by the Company and shall have no liability for any use or installation of any products (whether manufactured by the Company or other manufacturers) not specifically authorized by this sale. Purchaser acknowledges various warnings by the Company regarding the products and its installation and use. If the Company incurs any claims, lawsuits, settlements, or expenses (including attorney fees) for any loss, injury, death or property damage including, but not limited to, claims arising out of the Purchaser's or any end user's installation or use of the products, the Purchaser shall indemnify and hold the Company harmless.