INSTALLATION & MAINTENANCE INSTRUCTIONS

Models TIB

RECEIVING AND INSPECTION

Immediately upon receipt of a shipment, carefully inspect for damage and shortage. Turn the impeller by hand to see that it turns freely and does not bind. If any damage and/or shortage is detected or suspected, the carrier must be asked to conduct an inspection. The consignee's representative should not accept a shipment without a notation on the delivery receipt indicating items not delivered or the apparent extent of damage.

When a shipment is opened and damage is found which was not evident externally (concealed damage), it is mandatory that the consignee request an immediate inspection by the carrier. Report any damage to the carrier within 15 days. Failure to report damage within the above time limit will result in rejection of a claim.

HANDLING

CAUTION! This fan has rotating parts and safety precautions must be exercised during its handling, installation, operation and maintenance.

When handling fans and their accessories, always use equipment and methods that will not cause damage. Fans should be lifted using slings and padding or spreaders to avoid damage.

Make sure that all lifting and handling equipment and techniques conform to current safety standards.

Avoid lifting fans in a way that will bend or distort fan parts. Never pass slings or timbers through the orifices of fan.

Fans with special coatings or paints must be protected in handling to prevent damage.

STORAGE

Fans are protected against damage during shipment. If they cannot be installed and put into operation immediately upon receipt certain precautions are necessary to prevent deterioration during storage. Responsibility for integrity of fans and accessories during storage must be assumed by the user. The manufacturer will not be responsible for damage during storage. These suggestions are provided solely as a convenience to the user, who shall make his own decision as to whether to use any or all of them.

INDOOR: The ideal storage environment for fans and accessories is indoors, above grade, in a low humidity atmosphere which is sealed to prevent the entry of blowing dust, rain, or snow. Temperatures should be evenly maintained at between 70°F and 105°F (wide temperature swings may cause condensation and "sweating" of metal parts). Windows should be covered to prevent temperature variations caused by sunlight. Provide thermometers and humidity indicators at several points and maintain the atmosphere at 40% relative humidity, or lower.

It may be necessary to use trays of renewable desiccant or portable dehumidifier to remove moisture from the air in the storage enclosure.

Thermostatically controlled portable heaters (vented to outdoors) may be required to maintain even temperatures inside the enclosure.

CAUTION! Provide fire extinguishers, or fire alarms, or emergency response communication to protect building and equipment against fire damage. Be sure that building and storage practices meet all local, state and federal fire and safety codes.

The following fans or accessories must be stored indoors, in a clean dry atmosphere:

- a. Propeller wall fans not in wall housings.
- b. Any fan that is protected by a cardboard carton.
- c. Motors dismounted from fans.
- d. Spare wheels or propellers.
- e. Belts, sheaves, bushings and other parts when not mounted on fan.
- f. Boxes, bags or cartons of hardware.
- g. Curbs
- h. Dampers

Remove any accumulations of dirt, water, ice or snow and wipe dry before moving indoor storage. Allow cold parts to reach room temperature to avoid "sweating" of metal parts. Open boxes or cartons. Remove any accumulated moisture; if necessary use portable electric heaters to dry parts and packages. Leave coverings loose to permit air circulation and to permit periodic inspection.

Rotate wheels or propellers by hand to distribute bearing grease over the entire bearing surfaces.

Store at least 3 ½" off the floor on wooden blocks covered with moisture proof paper or polyethylene sheathing. Provide aisles between parts and along all walls, to permit air circulation and space for inspection.

OUTDOOR: Fans designed for outdoor use may be stored outdoors, if absolutely necessary. The storage area should be reasonably level and drained or ditched to prevent accumulation of water. Fencing and lighting for security are desirable. Roads or aisles for portable cranes and hauling equipment are needed. Consider the use of drift fencing to minimize accumulation of blowing snow or dirt.

The following fans may be stored outdoors, if dry indoor storage space is not available:

- a. Fans intended for outdoor use that are crated in wood.
- b. Wall fans installed in wall housings.

All fans must be supported on wooden blocks or timbers above water or normal snow levels. Provide enough blocking to prevent settling into soft ground. Fans should be set in place using the directional arrow markings on the crate as a guide.

Locate pieces far enough apart to permit air circulation, sunlight, and space for periodic inspection. Place all parts on their supports so that rain water will run off, or to minimize water accumulation. **Do not** cover parts with plastic film or tarps-these cause condensation of moisture from the air passing through heating and cooling cycles.

Fan wheels and propellers should be blocked to prevent spinning caused by strong winds.

INSPECTION AND MAINTENANCE DURING STORAGE

Inspect fans and accessories at least once per month, while in storage. Log results of inspection and maintenance performed. A typical log entry should include the following:

- a. Date
- b. Inspector's Name
- c. Name of Fan
- d. Location
- e. Condition of Paint or Coating
- f. Is moisture present?
- g. Is dirt accumulated?
- h. Corrective steps taken?

If moisture or dirt accumulations are found on parts, the source should be located and eliminated. Fans should be rotated at each inspection by hand ten to fifteen revolutions to redistribute the motor and bearing lubricant.

If paint deterioration begins, consideration should be given to touch-up or repainting. Fans with special coatings may require special techniques for touch-up or repair.

Machined parts coated with rust preventive should be restored to good condition promptly if signs of rust occur. The most critical items are pulleys, shafts and bearing locking collars. At the first sign of rusting on any of the above parts, remove the original rust preventive coating with petroleum solvent and clean lint-free cloths. Polish any remaining rust from surfaces with crocus cloth or fine emery paper and oil. **Do not** destroy the continuity of the surfaces. Wipe clean with lint-free cloths and recoat surfaces evenly and thoroughly with Tectly 506 (Ashland Oil Company) or equal. For hard to reach internal surfaces or for occasional use, consider using Tectly 511M Rust Preventive or WD40 or equal.

REMOVING FROM STORAGE

As fans are removed from storage to be installed in their final location, they should be protected and maintained in similar fashion, until the fan equipment goes into operation.

INSTALLATION

1. These fans can be operated only if the exhausted air and the surrounding environment are always free of flammable gases, vapors, or liquids, combustible dusts or ignitable fibers or flyings. **The fans cannot be used in hazardous environments where the fans electrical system could provide ignition to combustible or flammable materials.** The installation of the product must comply with all local and national safety codes including the National Electrical Code (NEC) and the National Fire Protection Act (NFPA).
2. **WARNING!** If gases, other than clean air, are to be exhausted using the fan, then the user bears the responsibility of determining that the fan is appropriate and safe for the application.
3. Remove fan from package and inspect within 15 days after receipt. If damaged, report damage to carrier. Motor and drives (motor pulley and belts) may be shipped separate from the fan.
4. Before installing, check all fasteners for tightness; particularly the propeller and shaft for torque requirements see table on page 4.

Turn the impeller by hand to make sure it does not strike the orifice. If it does hit, remove bearing cover and

loosen bolts holding bearings to fan frame. This will allow centering of shaft and impeller in the fan housing. To move the shaft in the bearings, remove bolts and top half of bearing shell, then loosen set screws on the bearings, and slide the shaft through the bearings.

If fan is equipped with pillow block bearings, loosen the set screws holding bearings to shaft and slide the shaft through the bearings. Tighten all set screws. (See Maintenance section for bearing replacement).

5. If motor is not factory mounted, set motor on fan motor base so that the shaft extends over the belt tube and fan shaft. To attach motor to base use four bolts and nuts which match holes in base. Before tightening, slide the motor toward the belt tube to take out all slack in the bolts. This insures the motor shaft is square with the fan. Tighten the motor bolts.
6. Slide the motor pulley onto the motor shaft and insert the square key into the keyway. Leave the pulley loose. Put the belt(s) over the fan and motor sheaves.

In some cases, it may be helpful to remove the bearing cover for access to the fan sheave. Align the belts and set belt tension. Motor base jack screws and locknuts are provided with each fan. They should be screwed into the weld nuts on the motor base to set belt tension.

The belt should depress its width when pressed firmly inward at midpoint between the pulleys.

Tighten set screw on motor pulley. For torque requirements see table on page 4.

7. Securely support unit and attach duct work. Attach any options at this point.
8. **WARNING!** Before proceeding, make sure electrical service to fan is locked in "OFF" position.
9. All wiring should be in accordance with local ordinances and the National Electrical Code.
10. Before electrical connections are made, the supply voltage, phase and ampere capacity must be checked for compatibility with the fan motor. In addition, the supply wiring must be properly fused and conform to local and national electrical codes. **WARNING!** Electrical connections that do not exactly match the motor nameplate may cause fire.

Leave enough slack in the wiring to allow for vertical movement of the motor as necessary.

11. **WARNING!** Unguarded rotating parts will be exposed during this procedure. Operate under power and compare impeller rotation with directional arrow on the fan.

Operation in reverse direction (opposite the rotation arrow marked on the fan) will deliver reduced air but will overload the motor.

In the case of three phase motors, the rotation can be reversed by interchanging any two (2) of the three (3) motor leads.

In the case of single phase motors, the reversing instructions will appear on the wiring diagram in the motor wiring compartment if reversing is possible.

12. **WARNING!** Inlet, discharge and drive guards must be installed when fan is within reach of personnel or within eight (8) feet (2.5 m) of working level or when deemed advisable for safety.

OPTIONAL ACCESSORY MOUNTING INSTRUCTIONS

GUARDS

1. Remove guard and bag of hardware from package.
2. Place guard on inlet or outlet flange.
3. Align eight holes on flange (six on size 12) with holes on guard. Secure with supplied hardware.

COMPANION FLANGES

1. Remove companion flanges and bag of hardware from package.
2. Place one companion flange on each fan flange.
3. Align eight holes of fan flange (six on size 12) with holes on companion flange. Secure with supplied hardware.

WEATHER COVER

1. Remove weather cover, weather cover rails attached to the weather cover and bag of hardware from package.
2. Place weather cover rails along side motor base rails with the (2) .45" diameter holes placed on the impeller end of the fan assembly. Secure with supplied bolts and nuts to motor base rails.
3. Place weather cover sides inside the weather cover rails. A notch in the weather cover allows for the clearance of the lube fittings when optional relubricated bearings are specified. The notched end of the weather cover is placed on the end of the weather cover rails with the (2) .45" diameter holes.
4. Secure with supplied bolts through weather cover rails to j-nuts on cover.

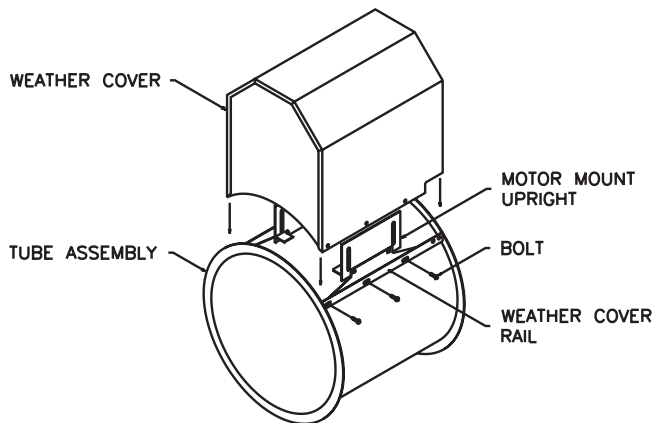

MOUNTING BASE

1. Attach mounting base ends to fan flange with supplied hardware. Motor location may be rotated in 45 degree increments.
2. Attach mounting base sides to mounting base ends with supplied hardware.
3. Check all fasteners for tightness.

DRIVE GUARD

1. Assemble and install drive guard according to included instructions.

OPERATION

These fans must be operated in such a way that the air surrounding their exterior is always free of flammable gases, vapors, or liquids, combustible dusts or ignitable fibers or flyings.

When exhausting air with the fan adequate intake area for supply air must be provided at all times.

MAINTENANCE

1. **CAUTION!** Before proceeding, make sure electrical service to fan is locked in the "OFF" position.

WINDMILLING: Even when the power supply is locked out, fans may cause injury or damage if the impeller is subject to "windmilling" which is the turning of the impeller and drive components due to a draft in the system. To guard against this hazard, the impeller should be secured to physically restrict rotational movement.

2. The set screws holding impeller and bearings to the shaft must be maintained in accordance with the **SET SCREW TIGHTENING SCHEDULE and PROCEDURE FOR TIGHTENING SET SCREWS IN BEARINGS AND HUBS.**
3. The inside of the belt well, the belts and surfaces of bearing units, and the inside of the shaft/bearing compartment must be checked for deposits on maximum three month intervals. The deposits must be removed if present.

All inner surfaces of the fan, including the impeller, exposed to the exhaust air should be checked for deposits on maximum three month intervals. The deposits must be removed if present.

4. Impeller shaft bearings should be inspected on maximum 3 month intervals.

Propeller shaft bearings are prelubricated, sealed and normally require no service. If a bearing is a source of noise and/or excessive heat or is losing lubricant it must be replaced. It is recommended that any bearing be replaced at a maximum five year period.

Optional pillow block bearings with external lubrication fittings under normal operation conditions will need no relubrication for 3 to 5 years. For normal operating conditions, use a grease conforming to NLGI No. 2. **CAUTION!** Do Not over lubricate. Lubricating bearings with a high pressure gun can blow bearing seals.

5. Motor bearings are prelubricated. Consult information printed on motor for lubrication instructions.
6. On belt driven units, check belt tension after first 48 hours of operation and thereafter annually. Belt should depress its width when pressed firmly inward at midway point between the pulleys. Too much tension will damage bearings. The belt should be tight enough to prevent slippage. When replacing worn belt, replace motor pulley if "shoulder" is worn in groove. **WARNING!** Do not replace the motor pulley with a larger diameter pulley. **Do not** replace fan pulley with one smaller in diameter. The pulley

ratios are set so that the motor will not be overloaded. **Do not** operate at higher speeds than rated in catalog.

7. If a motor requires replacement, the replacement must match all motor nameplate data from the original motor (service factor of replacement motor may be higher than original).
8. To remove impeller on sizes 10-18 loosen set screw above keyway on hub core. To remove impeller on sizes 20-36 remove roll pin on outside of impeller hub core by driving out with a drift pin and loosening two set screws on the inside of the prop hub core.
9. For duplex split pillow block bearings, install new bearings into new neoprene rings, check correct position of propeller with the fan housing, position the bearings in the die-formed recess and tighten the set screw. Replace the die-formed bearing cap and tighten the four bolts.

If unitary pillow block type bearings are used, slide bearings on to the shaft to desired location and bolt the bearing block securely to the support base. Slide the shaft back and forth in secured bearing (do not drive with a hammer) and rotate to make certain that it turns freely. Check the correct position of the impeller at the orifice. Impeller should not strike any part of the orifice and clearance between the impeller and the orifice should be the same all the way around.

Use the **PROCEDURE FOR TIGHTENING SET SCREWS IN BEARINGS AND HUBS** to tighten set screws.

10. Recommended spare parts is listed on page 5.

SET SCREW TIGHTENING SCHEDULE

1. Before initial operation of the fan, tighten set screws according to the procedure outlined below.
2. After 500 operating hours or three months, whichever comes first, tighten set screws to the full recommended torque.
3. At least once a year, tighten set screws to the full recommended torque.

PROCEDURE FOR TIGHTENING SET SCREWS IN BEARINGS AND HUBS

One Set Screw Application

Using a torque wrench, tighten the set screw to the torque recommended in Table 1.

Two Set Screw Application

1. Using a torque wrench, tighten one set screw to half of the torque recommended in Table 1.
2. Tighten the second set screw to the full recommended torque.
3. Tighten the first set screw to the full recommended torque.

Table 1. Recommended Tightening Torque for Set Screws

Set Screw Diameter	Torque (in-lbs)
#10	35
1/4	80
5/16	126
3/8	240
7/16	384
1/2	744
9/16	1080
5/8	1500
3/4	2580
7/8	3600
1	5400

VARIABLE FREQUENCY DRIVES AND MOTORS

There are occasions when a Variable Frequency Drive (VFD) will cause poor motor performance and possible damage. To avoid these problems, the Company recommends the following:

1. Select compatible motor and VFD converter; if possible, the motor and the converter should be from the same manufacturer or at least the converter selected should be recommended by the motor manufacturer.
2. A motor shaft grounding system should be used to prevent motor bearing damage from eddy currents.

NOTE: The Company will not honor motor warranty claims if the customer fails to follow these recommendations.

Tubular Centrifugal Incline

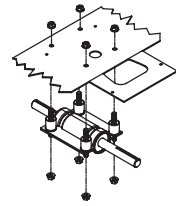
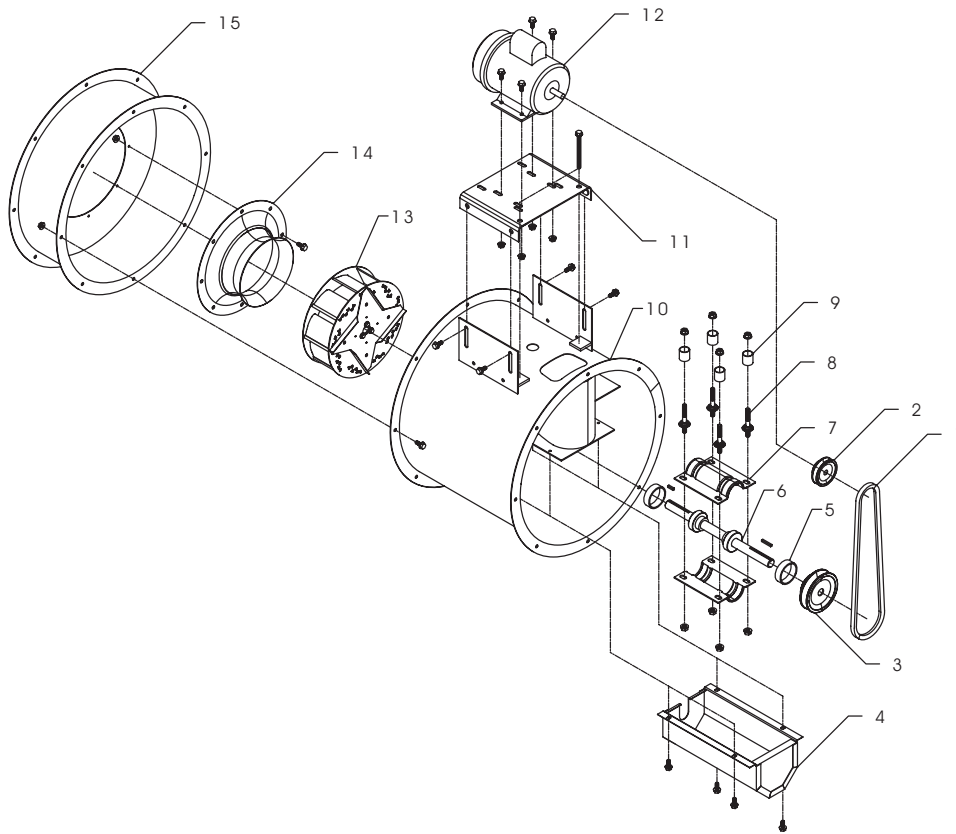

DETAIL OF SHAFT & BEARING ASSY

Parts List		
Ref. No.	Description	Qty.
1*	Belt	1
2	Motor Sheave	1
3	Sheave	1
4	Bearing Cover	1
5*	Rubber Ring	2
6*	Shaft & Bearing Assembly	1
7	Bearing Cap	2
8	Bearing Bolt	4
9	Bearing Support Post	4
10	Tube Assembly	1
11	Motor Base	1
12	Motor	1
13	Wheel Assembly	1
14	Orifice Assembly	1
15	Tube Extension Assembly	1

*Recommended Spare Parts

WHEN ORDERING REPLACEMENT PARTS, LIST MODEL, DESCRIPTION AND QUANTITY.

TERMS AND CONDITIONS OF SALE

ACCEPTANCE All orders and sales are subject to written approval and acceptance by an executive officer of Acme Engineering & Manufacturing Corporation at Muskogee, Oklahoma, (the "Company") and are not binding on the Company until so approved.

DELIVERY All shipping and delivery dates are estimated only. No delays in delivery will subject the Company to any costs, damages or fees for late delivery. Delivery of the products herein specified shall be made F.O.B. point of shipment, unless otherwise stated. The Company shall not be liable for delay due to causes beyond its reasonable control, such as Acts of God, acts of the purchaser, acts of civil or military authorities, priorities, fires, strikes, floods, epidemics, war, riots, delays in transportation, car shortages, and inability, due to reasons beyond its reasonable control, to obtain necessary labor, material, or manufacturing facilities. In the event of such a delay, the date of delivery shall be extended for a period equal to the time lost by reason of the delay.

TERMS OF PAYMENT If, in the judgment of the Company, the financial condition of the purchaser at any time does not justify continuation of manufacture or shipment on the terms of payment specified, the Company may require full or partial payment in advance.

Pro rata payments shall become due as shipments are made. Each shipment or delivery shall constitute a separate sale, and the default of any shipment or delivery shall constitute a separate sale, and the default of any shipment or delivery shall not vitiate the contract as to other shipments or deliveries.

SALES AND SIMILAR TAXES The Company's prices do not include sales, use, excise, or similar taxes. Consequently, in addition to the price specified herein, the amount of any present or future sales, use, excise, or other similar tax applicable to the sale of the product herein shall be paid by the Purchaser, or in lieu thereof

the Purchaser shall provide the Company with a tax exemption certificate acceptable to the taxing authorities.

CANCELLATION Any contract resulting from the Purchaser's order may be canceled by the Purchaser only by negotiations and upon payments of reasonable cancellation charges which will take into account expenses already incurred and commitments made by the Company.

DESIGN CHANGES The Company reserves the right to make changes in design, improvements and additions in and to its products any time without imposing any liability or obligations to itself to apply or install the same in any product manufactured by it.

TITLE The title and right of possession of the products sold herein shall remain with the Company and such products shall remain personal property until all payments herein (including deferred payments whether evidenced by notes or otherwise) shall have been made in full in cash and the Purchaser agrees to do all acts necessary to perfect and maintain such right and title in the Company.

PRICE ADJUSTMENTS Prices are subject to change upon notice by the Company. Prices on existing orders are subject to surcharges in the event of cost increases of metals and transportation. All complete component accessory material manufactured by others and furnished with the Company's products such as motors, drives, vibration equipment, controls or other completely assembled component structures, are subject to adjustment to the price at time of shipment regardless of the date of original order entry.

SAFETY ACCESSORIES The Company manufactures products designed to serve multiple applications and offers a wide range of safety equipment, including guards and other devices, as may be required to meet

customer specifications. Without exception, the Company recommends that all orders include applicable safety devices. Products ordered without applicable safety devices is clearly the responsibility of the Purchaser. Further, the Purchaser warrants that it has determined and acquired any and all safety devices required for products sold by the Company. Weather covers and guards for motor and V-belt drives, couplings, shafts and bearings, along with inlet and outlet screens, are optional accessories noted in the price list.

GOVERNING LAW The rights, obligations and remedies of Purchaser and the Company, the interpretation of these terms and conditions and the sale of products by the Company shall be governed by Oklahoma law, without regard to any principles of conflict of laws.

ARBITRATION Any dispute arising under or in connection with these terms and conditions or the sale of products shall be settled by binding arbitration administered by the American Arbitration Association under its Commercial Arbitration Rules, and judgment on the award rendered by the arbitrator may be entered in any court having jurisdiction thereof. The dispute shall be resolved by one neutral arbitrator who shall have no affiliation with either Purchaser or the Company and shall be selected by the American Arbitration Association office in Dallas, Texas. The arbitration proceedings shall be held in Muskogee, Oklahoma.

APPLICABLE DOCUMENTS The agreement between the Company and the Purchaser relating to the products includes these terms and conditions of sale, any applicable installation and maintenance instructions provided by the Company and any terms appearing on the Company's quotation, sales order acknowledgment and invoice.

WARNING Acme products are designed and manufactured to provide reliable performance but they are not guaranteed to be 100% free of defects. Even reliable products will experience occasional failures and this possibility should be recognized by the Purchaser and all End Users. If these products are used in a life support ventilation system where failure could result in loss or injury, the Purchaser and all End Users should provide adequate back-up ventilation, supplementary natural ventilation or failure alarm system, or acknowledge willingness to accept the risk of such loss or injury.

WARNING DO NOT use in HAZARDOUS ENVIRONMENTS where fan's electrical system could provide ignition to combustible or flammable materials unless unit is specifically built for hazardous environments. Comply with all local and national safety codes including the National Electrical Code (NEC) and National Fire Protection Act (NFPA).

CAUTION Guards must be installed when fan is within reach of personnel or within eight (8) feet (2.5 m) of working level or when deemed advisable for safety.

DISCLAIMER The Company has made a diligent effort to illustrate and describe the products accurately in all Company literature; however such illustrations and descriptions are for the sole purpose of identification and do not express or imply any warranty.

LIMITED WARRANTY

WARRANTY AND DISCLAIMER: The Company extends this limited warranty to the original purchaser and warrants that products supplied by the Company, shall be free from original defects in workmanship and materials for two years from date of shipment (except for the warranty periods noted for products listed below), provided same have been properly handled, stored, installed, serviced, maintained and operated. This warranty shall not apply to products which have been altered or repaired without the Company's express authorization, or altered or repaired in any way so as, in the Company's judgment, to affect its performance or reliability, nor which have been improperly installed or subjected to misuse, negligence, or accident, or incorrectly used in combination with other substances. The Purchaser assumes all risks and liability for results of use of all products.

Evaporative cooling pads are warranted to be free of defects in materials and workmanship for a period of two years from date of shipment provided same have been properly handled, stored, installed, serviced, maintained and operated; and further, not subjected to excessive heat, corrosive agents or chemicals, or mechanical abuse that may cause tearing, crushing or undue deterioration, nor used on a system or in a manner other than that for which it was designed as explained in the product literature.

The following products are warranted to be free of defects in materials and workmanship for the periods shown from date of shipment: Acme's exclusive duplex split pillow block bearings and shaft five years, belts one year, Polyethylene tubing 90 days, AIR40 Heater warranty one year, AIR40 Emitter warranty three years and DDP fan lifetime warranty on its propeller, cone, and housing.

LIMITATION OF REMEDY AND DAMAGES: All claims under this warranty must be made in writing and delivered to P. O. Box 978, Muskogee, Oklahoma, 74402, within 15 days after discovery of the defect and prior to the expiration of two years from the date of shipment by the Company of the product claimed defective, and Purchaser shall be barred from any

remedy if Purchaser fails to make such claim within such period.

Within 30 days after receipt of a timely claim, the Company shall have the option either to inspect the product while in Purchaser's possession or to request Purchaser to return the product to the Company at Purchaser's expense for inspection by the Company. The Company shall replace, or at its option repair, free of charge, any product it determines to be defective, and it shall ship the repaired or replacement product to Purchaser F.O.B. point of shipment; provided, however, if circumstances are such as in the Company's judgment to prohibit repair or replacement to remedy the warranted defects, the Purchaser's sole and exclusive remedy shall be a refund to the Purchaser of any part of the invoice price, paid to the Company, for the defective product or part.

The Company is not responsible for the cost of removal of the defective product or part, damages due to removal, or any expenses incurred in shipping the product or part to or from the Company's plant, or the installation of the repaired or replaced product or part.

The warranties set forth above do not apply to any components, accessories, parts or attachments manufactured by other manufacturers; such being subject to the manufacturer's warranty, if any. To the extent not prohibited by the manufacturer's warranty, the Company shall pass through to Purchaser such manufacturer's warranty.

THE COMPANY'S WARRANTY IS IN LIEU OF ALL OTHER WARRANTIES, EXPRESS OR IMPLIED, ARISING BY LAW OR OTHERWISE, INCLUDING WITHOUT LIMITATION THE IMPLIED WARRANTIES OF MERCHANTABILITY AND FITNESS FOR A PARTICULAR PURPOSE, WHICH ARE HEREBY EXPRESSLY DISCLAIMED AND WAIVED. THIS WARRANTY CONSTITUTES THE COMPANY'S SOLE AND EXCLUSIVE WARRANTY FOR DEFECTIVE GOODS AND PURCHASER'S SOLE AND EXCLUSIVE REMEDY FOR DEFECTIVE PRODUCTS.

No employee, agent, dealer, or other person is authorized to give any warranties on behalf of the Company or to assume for the Company any other liability in connection with any of its products except in writing and signed by an officer of the Company.

REPLACEMENT PARTS If replacement parts are ordered, purchaser warrants that the original components in which these replacement parts will be placed are in satisfactory working condition, and

when said replacement parts are installed, the resultant installation will operate in a safe manner, at speeds and temperatures for which the original product was purchased.

TECHNICAL ADVICE AND RECOMMENDATIONS, DISCLAIMER: Notwithstanding any past practice or dealings or any custom of the trade, sales shall not include the furnishing of technical advice or assistance or system design. Any such assistance shall be at the Company's sole option and may be subject to additional charge.

The Company assumes no obligation or liability on account of any recommendations, opinions or advice as to the choice, installation or use of products. Any such recommendations, opinions or advice are given and shall be accepted at Purchaser's and End User's risk and shall not constitute any warranty or guarantee of such products or their performance.

LIMITATION OF LIABILITY The cumulative liability of the Company to the Purchaser and any other persons for all claims in any way relating to or arising out of the products, including, but not limited to, any cause of action sounding in contract, tort, or strict liability, shall not exceed the total amount of the purchase price paid for those products which are the subject of any such claim. This limitation of liability is intended to apply without regard to whether other provisions of this agreement have been breached or have proven ineffective even if the Company has been advised of the possibility of such claims or demands. In no event shall the Company be liable to the Purchaser or any other person for any loss of profits or any incidental, special, exemplary, or consequential damages for any claims or demands brought by the Purchaser or such other persons.

INDEMNITY The Company's maximum liability to Purchaser and to any end user is as set forth above. The Company makes no warranty to anyone for any products not manufactured by the Company and shall have no liability for any use or installation of any products (whether manufactured by the Company or other manufacturers) not specifically authorized by this sale. Purchaser acknowledges various warnings by the Company regarding the products and its installation and use. If the Company incurs any claims, lawsuits, settlements, or expenses (including attorney fees) for any loss, injury, death or property damage including, but not limited to, claims arising out of the Purchaser's or any end user's installation or use of the products, the Purchaser shall indemnify and hold the Company harmless.



ACME ENGINEERING AND MANUFACTURING CORPORATION
P.O. Box 978
Muskogee, Oklahoma 74402
Telephone 918/682-7791
Fax 918/682-0134
www.acmefan.com